

TOP VIEW

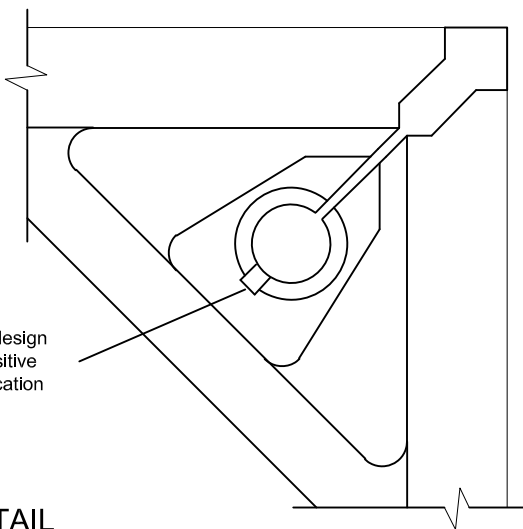

Integral shape pocket design and locating tab for positive lateral retention and location with or without screws

CORNER DETAIL

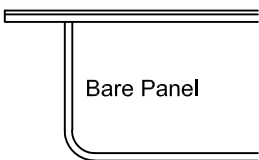

Bare Panel

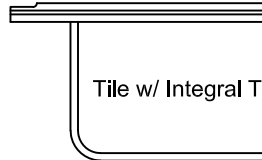

Tile w/ Integral Trim

System Performance Criteria

System performance criteria are the most important to consider because they represent the performance in a typical installation. Panel only criteria such as concentrated load is often used to specify floor systems however, the test is not representative of an actual installation because it is performed with the panel resting on blocks, not actual understructure.

System Performance Criteria (Tested on Actual Understructure)*								
System Type	Understructure	SYSTEM WEIGHT	STATIC LOADS			ROLLING LOADS		IMPACT LOADS
			Design Loads	Safety Factor (min 2.0)	Uniform Loads	10 Passes	10,000 Passes	
ConCore 1000-60cm	Posilock	8.0 lbs / ft ² 39 kg / m ²	1000 lbs 454 kg	Pass	250 lbs / ft ² 11.9 kPa	800 lbs 363 kg	600 lbs 272 kg	100 lbs 45 kg
	Bolted Stringer	9.5 lbs / ft ² 46 kg / m ²	1000 lbs 454 kg	Pass	250 lbs / ft ² 11.9 kPa	800 lbs 363 kg	600 lbs 272 kg	100 lbs 45 kg

*System load definitions and test procedure descriptions can be found in the Standard Product Tests and Methodology Guidelocated in the Resources section of Tate's web-site, www.tateaccessfloors.com.

SPECIFICATIONS

General information

- 60cm module. Panel weight : 8.0 lbs./ft² (39kg/m²) bare.
- All steel welded construction filled internally with a cementitious core material.
- Protected from corrosion by an epoxy paint finish.
- Class A flame spread rating.
- Non-combustible material.

UNDERSTRUCTURE OPTIONS

- Freestanding
- Posilock
- 60cm Bolted Stringer
- 120cm Bolted Stringer

COVERING OPTIONS

Tile factory laminated with integral trim edge

- 1/8" HPL _____ (Color) _____
- 1/16" HPL _____ (Color) _____
- 1/8" Conductive HPL _____ (Color) _____
- 1/16" Conductive HPL _____ (Color) _____

For additional laminate options contact Inside Sales

Bare Painted Panel Options

- Bare Painted Finish to accept carpet tile application